

# SHORT FORM SPECIFICATION

## **I•CODE SLI SL2 ICS20 Smart Label IC**

Short Form Specification

April 2002

Revision 1.1

**Smart Label ISO IC****SL2 IC S20****CONTENTS**

1	FEATURES.....	3
1.1	I <sup>2</sup> C/SPI RF Interface (ISO 15693).....	3
1.2	EEPROM.....	3
1.3	Security .....	3
2	GENERAL DESCRIPTION.....	4
2.1	Contactless Energy and Data Transfer.....	4
2.2	Anticollision.....	4
2.3	Security .....	4
3	FUNCTIONAL DESCRIPTION.....	5
3.1	Block Description.....	5
3.2	Memory Organisation.....	6
3.2.1	Configuration of delivered ICs.....	6
3.2.2	Unique Identifier .....	6
3.2.3	Application Family Identifier.....	6
3.2.4	Write Access Conditions .....	7
3.3	Communication Principle.....	7
3.4	Supported commands .....	7
3.4.1	Mandatory commands.....	7
3.4.2	Optional commands.....	7
3.4.3	Custom specific commands .....	10
3.5	Data Integrity.....	15
3.6	RF Interface .....	15

**Note: Specification may be changed without further notice.**

---

**Smart Label ISO IC****SL2 IC S20**

---

**1 FEATURES****1.1 I-CODE SLI RF Interface (ISO 15693)**

- Contactless transmission of data and supply energy (no battery needed)
- Operating distance: Up to 1.5m (depending on antenna geometry)
- Operating frequency: 13.56 MHz (ISM, world wide licence free available)
- Fast data transfer: up to 53 kbit/s
- High data integrity: 16 Bit CRC, framing
- True anticollision
- Electronic Article Surveillance (EAS)
- Application Family Identifier (AFI) supported
- Data Storage Format Identifier (DSFID)
- Additional fast anticollision read
- Write distance equal to read distance

**1.2 EEPROM**

- 896 bits for user data, organised in 28 blocks of 4 byte each
- User definable access conditions for memory blocks 0 to 27
- Data retention of 10 years.
- Write endurance 100.000 cycles

**1.3 Security**

- Unique identifier for each device
- Lock mechanism for each block (write protection)
- Lock mechanism for DSFID, AFI, EAS

---

**Smart Label ISO IC****SL2 IC S20**

---

**2 GENERAL DESCRIPTION**

The I•CODE SLI IC is a dedicated chip for intelligent label like supply chain management as well as baggage and parcel identification in airline business and mail services. This IC is the first member of a product family of smart label ICs based on the ISO standard ISO 15693.

The I•CODE system offers the possibility of operating labels simultaneously in the field of the reader antenna (*Anticollision*). It is designed for long range applications.

**2.1 Contactless Energy and Data Transfer**

Whenever connected to a very simple and cheap type of antenna (as a result of the 13.56 MHz carrier frequency) made out of a few windings printed, wound, etched or punched coil the I•CODE SLI IC can be operated without line of sight up to a distance of 1.5 m (gate width). No battery is needed. When the smart label is positioned in the field of an interrogator antenna, the high speed RF communication interface allows to transmit data with up to 53 kbit/s.

**2.2 Anticollision**

An intelligent anticollision function allows to operate more than one tag in the field simultaneously. The anticollision algorithm selects each tag individually and ensures that the execution of a transaction with a selected tag is performed correctly without data corruption resulting from other tags in the field.

**2.3 Security**

Unique Identifier, which can not be altered, guarantee the uniqueness of each label

**Smart Label ISO IC**

**SL2 IC S20**

**3 FUNCTIONAL DESCRIPTION**

**3.1 Block Description**

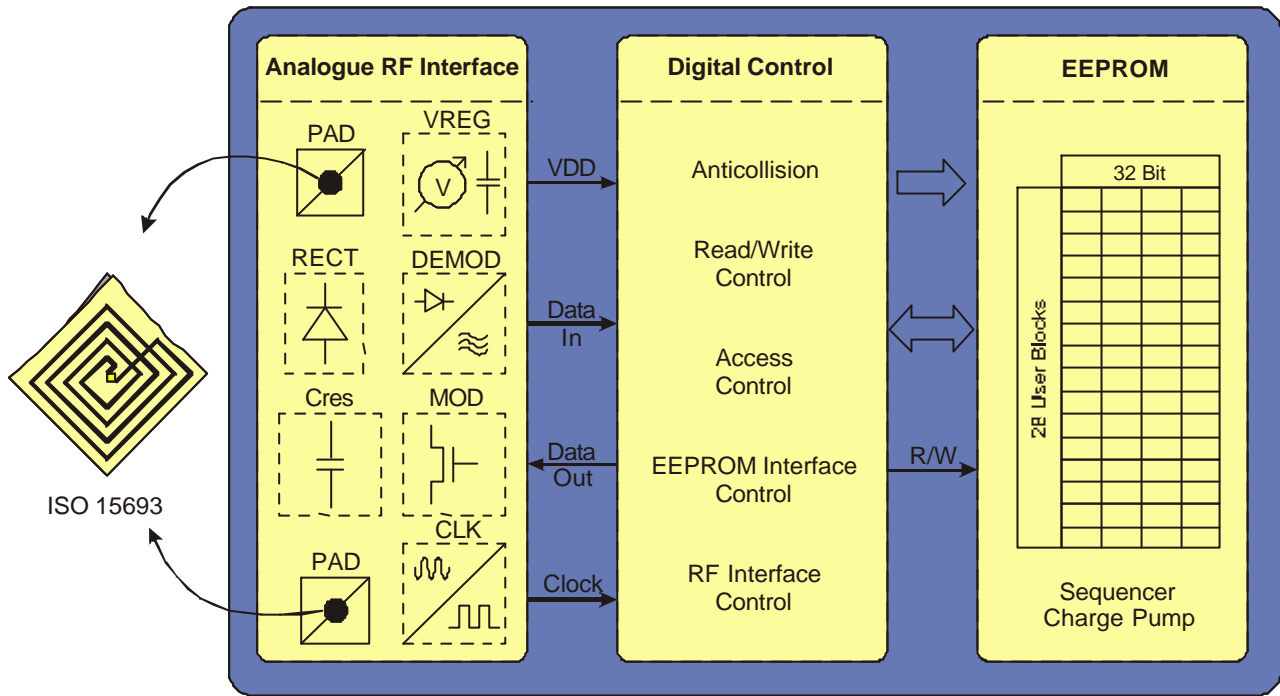

The label requires no internal power supply. Its contactless interface generates the power supply and the system clock via the resonant circuitry by inductive coupling to the interrogator. The interface also demodulates data that are transmitted from the interrogator to the I•CODE Label, and modulates the electromagnetic field for data transmission from the I•CODE Label to the interrogator.

**Smart Label ISO IC**

**SL2 IC S20**

**3.2 Memory Organisation**

The 896 bit EEPROM user memory is divided into 28 blocks. A block is the smallest access unit. Each block consists of 4 bytes (1 block = 32 bits). Bit 0 in each byte represents the least significant bit (LSB) and bit 7 the most significant bit (MSB), respectively.

The contents of the blocks are **not** defined at delivery.

All blocks can be addressed by read and write commands.

3.2.1 CONFIGURATION OF DELIVERED ICS

I•CODE SLI ICs are delivered with the following configuration by Philips:

- Unique Identifier is unique and read only
- Write Access Conditions allow to change all blocks (with the exception of both UID blocks).
- Status of EAS mode is **not** defined
- AFI is supported and **not** defined
- DSFID is supported and **not** defined
- User Data memory is **not** defined

3.2.2 UNIQUE IDENTIFIER

The 64 bit unique identifier (UID) is programmed during the production process according to ISO/IEC 15693-3 and cannot be changed afterwards.

The numbering of the 64 bits is done according to ISO/IEC 15693-3 starting with the LSB 1 and ending with the MSB 64. This is in contrast to the general used bit numbering within a byte.

The TAG type is a part of the UID (bit41 to 48, after the manufacturer code which is "04" hex for Philips Semiconductors).

The TAG type of the SL2 ICS20 is "01" hex.

MSB				LSB					
64	57	56	49	48	41	40	1		
"E0"		"04"		"01"		<i>IC manufacturer serial number</i>			
UID 7	UID 6		UID 5		UID 4	UID 3	UID 2	UID 1	UID 0

3.2.3 APPLICATION FAMILY IDENTIFIER

The I•CODE system offers the feature to use an Application Family Identifier (AFI) at the *inventory* command and the two custom commands *inventory read* and *fast inventory read* (this allows for example the creation of 'label families').

For details please refer to ISO 15693-3.

---

**Smart Label ISO IC****SL2 IC S20**

---

**Write Access Conditions**

Each block in the user memory can be individually write protected (please see 3.4.2.3). Write protected blocks can never be written to from this moment on.

**3.3 Communication Principle**

For detailed description of the protocol and timing please refer to ISO 15693-2 (modulation, bit-coding, framing) and 15693-3 (anticollision, timing, protocol).

**3.4 Supported commands****3.4.1 MANDATORY COMMANDS***3.4.1.1 Inventory*

As defined in ISO/IEC 15693-3.

*3.4.1.2 Stay quiet*

As defined in ISO/IEC 15693-3.

**3.4.2 OPTIONAL COMMANDS***3.4.2.1 Read single block*

As defined in ISO/IEC 15693-3.

Option 0 (option flag not set) is supported.

Option 1 (option flag set) is supported.

*3.4.2.2 Write single block*

As defined in ISO/IEC 15693-3.

Only Option 0 (option flag is not set) is supported.

*3.4.2.3 Lock block*

As defined in ISO/IEC 15693-3.

Only Option 0 (option flag is not set) is supported.

---

**Smart Label ISO IC****SL2 IC S20**

---

**3.4.2.4 Read multiple blocks**

As defined in ISO/IEC 15693-3.

Option 0 (option flag is not set) is supported.

Option 1 (option flag set) is supported.

Note: If the sum of first block number and number of blocks exceeds the total available number of user blocks the number of transmitted blocks is less than the requested number of blocks, which means that the last returned block is the highest available user block, followed by the 16 bit CRC and the EOF.

**3.4.2.5 Select**

As defined in ISO/IEC 15693-3.

**3.4.2.6 Reset to ready**

As defined in ISO/IEC 15693-3.

**3.4.2.7 Write AFI**

As defined in ISO/IEC 15693-3.

Only Option 0 (option flag is not set) is supported.

**3.4.2.8 Lock AFI**

As defined in ISO/IEC 15693-3.

Only Option 0 (option flag is not set) is supported.

**3.4.2.9 Write DSFID**

As defined in ISO/IEC 15693-3.

Only Option 0 (option flag is not set) is supported.

**3.4.2.10 Lock DSFID**

As defined in ISO/IEC 15693-3.

Only Option 0 (option flag is not set) is supported.



---

**Smart Label ISO IC****SL2 IC S20**

---

*3.4.2.11 Get system information*

As defined in ISO/IEC 15693-3.

The TAG type of the SL2 ICS20 is "01" hex.

*3.4.2.12 Get multiple block security status*

As defined in ISO/IEC 15693-3.

Note: If the sum of first block number and number of blocks exceeds the total available number of user blocks the number of transmitted security status bytes is less than the requested number, which means that the last returned status byte is the one corresponding to the highest available user block, followed by the 16 bit CRC and the EOF.

**Smart Label ISO IC**

**SL2 IC S20**

3.4.3 CUSTOM SPECIFIC COMMANDS

The manufacturer code of Philips is defined in ISO 7816-6A1. It has the value of 04hex.

For the structure of custom specific commands please refer to 15693-3.

3.4.3.1 *Inventory read*

**Command Code = A0 hex**

When receiving the *inventory read* request, the **ICODE** SLI IC performs the same as in the anti-collision sequence, with the difference that instead of the UID and the DSFID the requested memory content is re-transmitted from the **ICODE** SLI IC.

If an error is detected the **ICODE** SLI IC remains silent.

If the option flag is set to 0 n blocks of data are re-transmitted. If the option flag is set to 1 n blocks of data and the part of the UID which is not part of the mask and slot number are re-transmitted.

The request contains:

- Flags
- *Inventory read* command code
- IC Manufacturer code ("04" hex)
- AFI (if the AFI flag is set)
- Mask length
- Mask value (if mask length >0)
- First block number to be read
- Number of blocks to be read
- CRC 16

SOF	Flags	Inventory Read	IC Mfg. code	Optional AFI	Mask Length	Mask Value	First block number	Number of blocks	CRC16	EOF
	8 bits	8 bits	8 bits	8 bits	8 bits	0 – 64 bits	8 bits	8 bits	16 bits	

The `Inventory_flag` must be set to 1.

The meaning of flags 5 to 8 is according to table 5 in ISO/IEC 15693-3.

The number of blocks in the request is one less than the number of blocks that the **ICODE** SLI IC returns in its response.

**Smart Label ISO IC**

**SL2 IC S20**

If the Option flag in the request is set to 0 the response contains:

SOF	Flags	Data	CRC16	EOF
	8 bits	Block Length	16 bits	
		Repeated as needed		

The I•CODE SLI IC reads the requested block(s) and sends back their value in the response. The mechanism and timing of the *Inventory read* command performs the same as at the *Inventory* command which is described in Clause 8 of ISO/IEC 15693-3.

If the Option flag in the request is set to 1 the response contains:

SOF	Flags	Rest of UID which is not part of the mask and slot number	Data	CRC16	EOF
	8 bits	0 to 64 bit	Block Length	16 bits	
		Multiple of 8 bits	Repeated as needed		

The I•CODE SLI IC reads the requested block(s) and sends back their value in the response. Additionally the bytes of the UID, which are not parts of the mask and the slot number in case of 16 slots, are returned. Instead of a padding with zeros up to the next byte boundary the corresponding bits of the UID are returned. The mechanism and timing of the *Inventory read* command perform the same as at the *Inventory* command which is described in Clause 8 of ISO/IEC 15693-3.

Note: The number of bits of the re-transmitted UID can be calculated as follows:

- 16 slots: 64 - 4 - mask length rounded up to the next byte boundary
- 1 slot : 64 - mask length rounded up to the next byte boundary

Note: If the sum of first block number and number of blocks exceeds the total available number of user blocks the number of transmitted blocks is less than the requested number of blocks, which means that the last returned block is the highest available user block, followed by the 16 bit CRC and the EOF.

**Smart Label ISO IC**

**SL2 IC S20**

Example: mask length=30

Returned:  $64-4-30=30$  gives 4 bytes

Byte0	Byte1	Byte2	Byte3	Byte4	Byte5	Byte6	Byte7	UID	
mask value incl. padding with zeros									transmitted by Interrogator
				returned value				transmitted by <b>•</b> CODE SLI IC	

*3.4.3.2 Fast inventory read*

**Command Code = A1 hex**

When receiving the *fast inventory read* command the **•**CODE SLI IC behaves the same as in the *inventory read* command with the following exceptions:

The datarate in the direction **•**CODE SLI IC to the interrogator is twice as defined in ISO/IEC 15693-3 (depending on the *datarate\_flag* 53 kbit/s (high datarate) or 13 kbit/s (low datarate)).

The datarate from the interrogator to the **•**CODE SLI IC and the time between the rising edge of the EOF from the interrogator to the response of **•**CODE SLI IC remain unchanged (stay the same as defined in ISO/IEC 15693-3).

In the direction **•**CODE SLI IC to the interrogator only the single subcarrier mode is supported.

**Smart Label ISO IC****SL2 IC S20****3.4.3.3 Set EAS****Command Code = A2 hex**

This command sets the EAS bit to 1.

Request format

SOF	Flags	Set EAS	IC Mfg. code	UID	CRC16	EOF
	8 bits	8 bits	8 bits	64 bits	16 bits	

Response format when Error\_flag is set

SOF	Flags	Error Code	CRC16	EOF
	8 bits	8 bits	16 bits	

Response format when Error\_flag is NOT set

SOF	Flags	CRC16	EOF
	8 bits	16 bits	

**3.4.3.4 Reset EAS**

This command sets the EAS bit to 0.

**Command Code = A3 hex**

Request format

SOF	Flags	Reset EAS	IC Mfg. code	UID	CRC16	EOF
	8 bits	8 bits	8 bits	64 bits	16 bits	

Response format when Error\_flag is set

SOF	Flags	Error Code	CRC16	EOF
	8 bits	8 bits	16 bits	

Response format when Error\_flag is NOT set

SOF	Flags	CRC16	EOF
	8 bits	16 bits	

**Smart Label ISO IC****SL2 IC S20****3.4.3.5 Lock EAS****Command Code = A4 hex**

This command locks the current state of the EAS bit.

Request format

SOF	Flags	Lock EAS	IC Mfg. code	UID	CRC16	EOF
	8 bits	8 bits	8 bits	64 bits	16 bits	

Response format when Error\_flag is set

SOF	Flags	Error Code	CRC16	EOF
	8 bits	8 bits	16 bits	

Response format when Error\_flag is NOT set

SOF	Flags	CRC16	EOF
	8 bits	16 bits	

**3.4.3.6 EAS Alarm****Command Code = A5 hex**

If the EAS bit is set to 1 the EAS response is returned from the ►CODE SLI IC

Request format

SOF	Flags	EAS	IC Mfg. code	UID	CRC16	EOF
	8 bits	8 bits	8 bits	64 bits	16 bits	

If an error is detected the ►CODE SLI IC remains silent

Response format

SOF	Flags	EAS sequence	CRC16	EOF
	8 bits	256 bits	16 bits	

---

**Smart Label ISO IC****SL2 IC S20**

---

EAS sequence (starting with the LSB, which is transmitted first; read from left to right):

```
11110100 11001101 01000110 00001110 10101011 11100101 00001001 11111110
00010111 10001101 00000001 00011100 01001011 10000001 10010010 01101110
01000001 01011011 01011001 01100001 11110110 11110101 11010001 00001101
10001111 00111001 10001011 01001000 10100101 01001110 11101100 11110111
```

If the EAS bit is set to 0 the **ICODE** SLI IC remains silent.

### 3.5 Data Integrity

Following mechanisms are implemented in the contactless communication link between interrogator and label to ensure very reliable data transmission:

- 16 bit CRC per block
- Bit count checking
- Bit coding to distinguish between "1", "0", and no information
- Channel monitoring (protocol sequence and bit stream analysis)

### 3.6 RF Interface

The definition of the RF-interface is according to the standard ISO/IEC 15693-2 and ISO/IEC 15693-3.

# ***Philips Semiconductors - a worldwide company***

## **Contact Information**

For additional information please visit <http://www.semiconductors.philips.com>. Fax: **+31 40 27 24825**  
For sales offices addresses send e-mail to: [sales.addresses@www.semiconductors.philips.com](mailto:sales.addresses@www.semiconductors.philips.com).

All rights are reserved. Reproduction in whole or in part is prohibited without the prior written consent of the copyright owner.

The information presented in this document does not form part of any quotation or contract, is believed to be accurate and reliable and may be changed without any notice. No liability will be accepted by the publisher for any consequence of its use. Publication thereof does not convey nor imply any license under patent- or other industrial or intellectual property rights.

